

Tideway®

Multi - Stage Pump (880203010) CH5-60

Features:-

CH5-60 multi stage pump: impeller and diffuser are made of PPO project plastic, SUS304 stainless steel for shaft, iron steel for inlet and outlet, advanced design, the performance reach the advanced level of similar product, it have the features of light, good looking, corrosive resistance, high head, efficiency, endurance, etc.

CH5-60 pump motor is special product which have F class insulation, IP55 class protection, it use NSK bearing, UL & VDE certified capacitor, super mechanical seal, thermal protection.

CH5-60 pump belong to non-selfpriming centrifugal pumps, input water from the direction of shaft which is longer than normal motor.

CH5-60 pump is suitable for agriculture, industrial, gardening, air-conditioning, cool circulation system, high building, water supply, boiler, fishing and so on.



Operation Conditions:-

CH5-60 pump is suitable for non-fire, explosive clean liquid which keep away from corrosive of PPO plastic. The temperature of liquid: from +5°C to 60°C, max ambient +40°C, max suction: 8 meter; max working pressure: 1Mpa, the max input pressure is limited by the max working pressure.

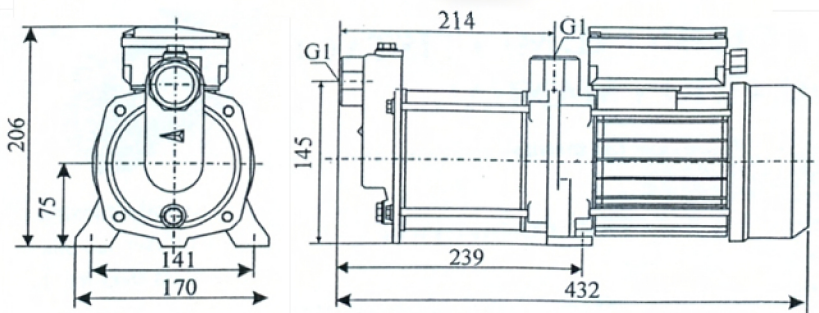
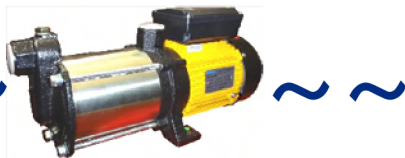

Performance Curve:-

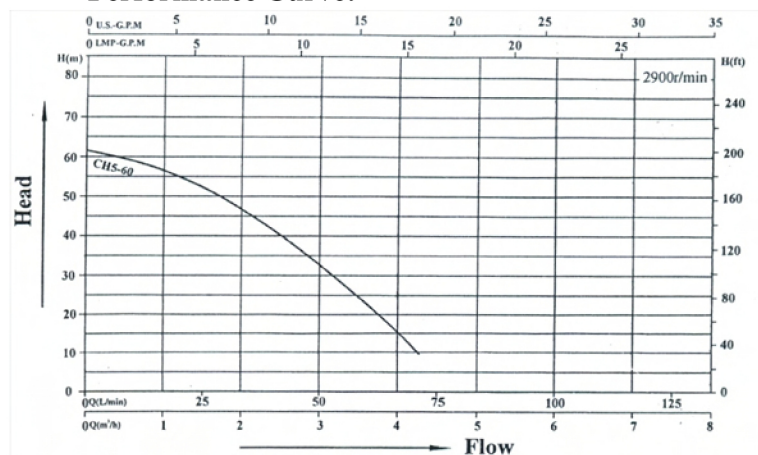

Power : 1.0 kW/6.1A
Voltage : 240V/50Hz
Speed : 2900rpm
Max. Head : 60m
Std. Head : 45m
Std. Flow : 2m³/h

***Product's specification may subject to change without further notice.
***Actual product may slightly differ from pictures shown.